

BOSCH

October 1997
INDUSTRIAL

DRYWALL DRIVER

Model 0601420739

1420VSR

(.739)

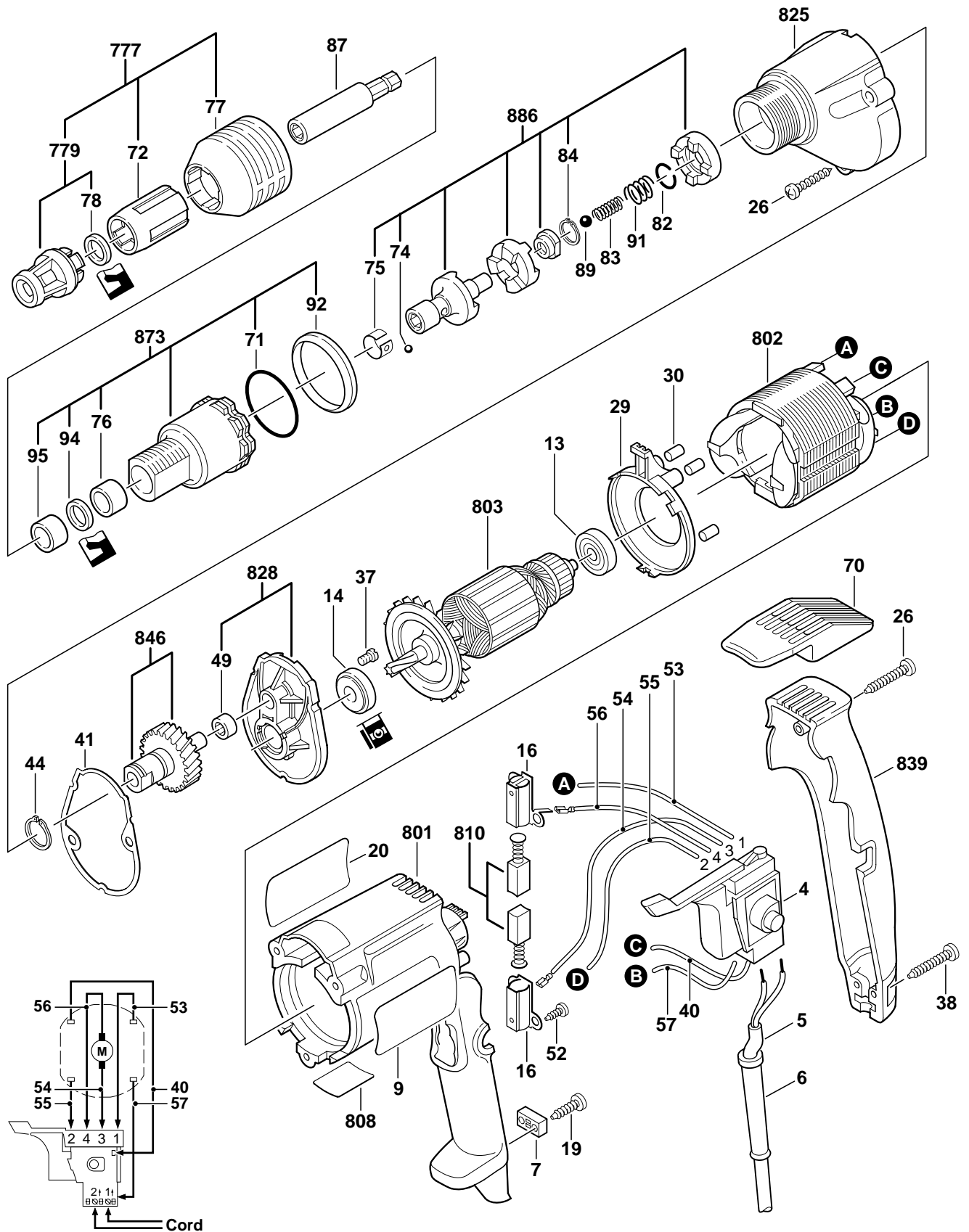

1420VSR (.739) DRYWALL DRIVER

Pos.	Part Number	Description {Qty}	F/C	Pos.	Part Number	Description {Qty}	F/C
4	3 607 200 523	Switch VSR	17	76	3 600 301 508	Bushing	82
5	3 604 460 555	Cord 120V 18/2	11	77	3 600 390 502	Locking Ring	91
6	2 600 703 013	Strain Relief	11	78	3 600 290 502	Seal	77
7	2 601 035 001	Cord Clamp	89	82	3 600 200 516	Spring Retainer	89
9	2 610 906 828	Label "1420VSR"	9	83	3 604 613 507	Spring	27
13	1 900 905 018	Ball Bearing	60	84	3 600 118 502	Retaining Ring	89
14	2 600 905 021	Ball Bearing	61	87	3 603 008 500	Bit Holder	9
16	2 604 337 003	Brush Holder {2}	25	89	1 903 230 011	Ball 6mm	66
19	2 910 611 019	Screw {2}	89	91	3 604 613 506	Spring	27
20	2 610 906 850	Label "Caution"	9	92	3 600 113 506	Insulating Sleeve	9
26	2 910 615 082	Screw {4}	89	94	3 600 290 503	Seal	77
29	3 600 590 505	Baffle	24	95	3 600 301 510	Bushing	82
30	3 602 391 503	Rubber Buffer {3}	24	777	3 600 552 509	Depth Guage Assembly w/pos. 72, 77, 779	91
37	2 914 411 045	Screw {2}	89	779	3 600 552 505	Depth Guage w/pos. 78	91
38	2 910 615 022	Screw {2}	89	801	3 605 108 557	Motor Housing	71
40	3 604 448 500	Cable 162mm	10	802	2 604 220 446	Field 120V	22
41	3 601 016 504	Gasket	79	803	3 604 011 584	Armature w/Fan 120V	AW
44	2 916 650 003	Retaining Ring	89	808	3 601 119 718	Nameplate	9
49	3 600 910 505	Needle Bearing	56	810	2 604 321 914	Brush Set	26
52	2 910 611 405	Screw {4}	89	825	3 605 190 512	Gear Housing w/Bearing	72
53	3 604 448 501	Cable 117mm	10	828	3 605 806 541	Intermediate Plate Assy. w/pos. 49	38
54	3 604 448 502	Cable 48mm	10	839	3 605 133 521	Handle Cover	74
55	3 604 448 503	Cable 78mm	10	846	3 606 120 565	Drive Shaft w/Gear	32
56	3 604 448 504	Cable 88mm	10	873	3 605 190 520	Clutch Housing Assembly w/pos. 71, 76, 92, 94, 95	82
57	3 604 448 505	Cable 122mm	10	886	3 606 441 503	Clutch Kit w/pos. 74, 75, 84	46
70	3 600 690 505	Belt Clip	9				
71	3 600 210 506	O-Ring	78				
72	3 600 360 505	Adjusting Sleeve	91				
74	1 903 230 006	Ball 3.5mm	66				
75	3 600 034 504	Spring Clip	9				

Service Notes:

To: All Authorized and Factory Service Centers,
Field Sales and Internal Support Personnel

Re: Switch Change for models

1000VSR	1021VSR	1028VSR	1420VSR	B6100
1001VSR	1022VSR	1029VSR	1420VSRSL	B6270
1002VSR	1023VSR	1404VSR	1421VSR	B6280
1003VSR	1026VSR	1404VSRSL	1422VSR	B6950
1020VSR	1027VSR	1405VSR	1422VSRQ	B6980

Please insert this bulletin into the "Technical Bulletins" section of your Bosch Parts Manual, only after making any additions or notes to your Illustrated Parts List(s).

Please be advised that a new switch configuration has been introduced for the above listed models. This change will take place in newer produced versions and effects all service requirements.

Switch Kit 2 610 994 891 contains:

<u>Pos.</u>	<u>Part Number</u>	<u>Description</u>
5/1	1 900 452 012	Terminal Sleeve {2}
18	2 603 410 001	Screw {2}
40	2 604 448 146	Cable 110mm {2}
53	2 604 448 137	Cable 80mm
54	2 604 448 100	Cable 68mm
57	2 604 448 104	Cable 60mm {2}
58	2 607 200 338	Reverse Switch

Use 2 610 994 891
Switch Kit

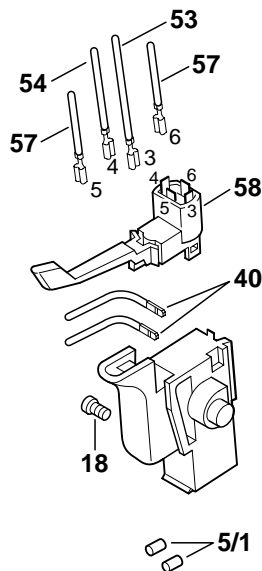

New Wiring Diagram

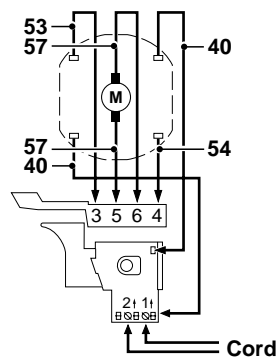

Old 3 607 200 523
No Longer Available

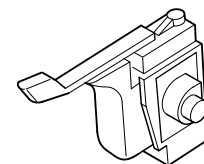

Note: The terminal sleeves (pos. 5/1) need to be installed on the tips of the power cord to insure a good connection with the switch. Rotation adjustments are accomplished by swapping the brush cables on the reverse switch (locations 5 & 6).

All questions should be directed to your Authorized Service Manager.

Product Service Department