

BOSCH

July 1998
INDUSTRIAL

ANGLE GRINDER
Model 0601754039

1754

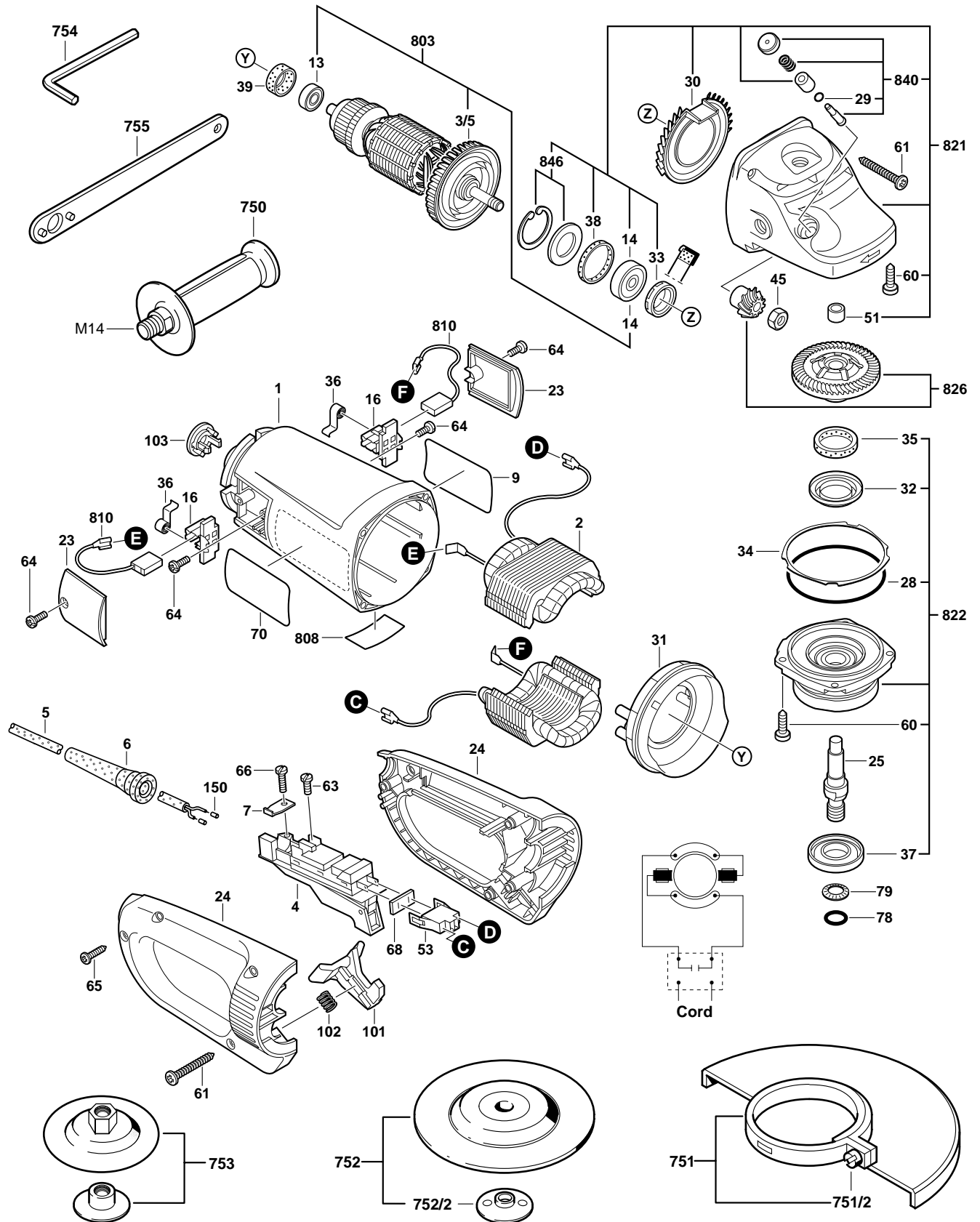

1754 ANGLE GRINDER

Pos.	Part Number	Description {Qty}	F/C	Pos.	Part Number	Description {Qty}	F/C
1	1 605 108 190	Motor Housing	71	66	2 910 611 019	Screw	89
2	1 604 220 339	Field 120V	22	68	1 601 006 011	Gasket	79
3/5	1 606 610 142	Fan	23	70	2 610 994 134	Label "Warning"	9
4	1 607 200 147	Switch On/Off 120V	15	78	1 900 210 111	O-Ring	78
5	1 604 460 092	Cord 120V 14/2	11	79	1 600 171 001	Washer	65
6	1 600 703 023	Strain Relief	11	150	1 900 452 003	Terminal Sleeve {2}	10
7	1 601 302 018	Cord Clamp	89	101	1 601 990 004	Lever	64
9	2 610 994 131	Label "1754"	9	102	1 604 616 022	Spring	27
13	3 600 900 512	Ball Bearing	52	103	1 602 388 035	Bushing	82
14	1 600 905 009	Ball Bearing	61	750	2 602 025 075	Auxiliary Handle	9
16	1 604 336 036	Brush Holder {2}	25	751	1 605 510 204	7" Guard w/pos. 751/2	92
23	1 605 500 206	Brush Cover {2}	9	751.1	1 605 510 205	9" Guard w/pos. 751/2	92
24	1 605 132 130	Handle Assembly	74	751/2	2 910 141 244	Screw	89
25	1 603 523 117	Spindle 5/8"-11	52	752	BP700	7" Sanding Backing Pad w/pos. 752/2	9
28	1 600 210 033	O-Ring	78	752.1	BP900	9" Sanding Backing Pad w/pos. 752/2	9
29	1 600 210 034	O-Ring	78	752/2	2 610 906 259	Pad Nut 5/8"-11	91
30	1 600 591 029	Air Deflector	24	753	2 610 906 326	Backing Flange Kit w/pos. 754	9
31	1 600 591 028	Air Deflector	24	754	1 607 950 038	Allen Wrench 3/8"	9
32	1 600 290 019	Sealing Ring	77	755	2 610 906 253	Spanner Wrench	9
33	1 600 290 013	Oil Seal	77	803	1 604 011 181	Armature w/Fan 120V w/pos. 3/5, 13, 14	AW
* 34	1 600 190 020	Shim 0.15mm	65	808	1 601 106 999	Nameplate	9
* 34.1	1 600 190 021	Shim 0.3mm	65	810	1 607 014 130	Brush Set	26
* 34.2	1 600 190 022	Shim 0.1mm	65	821	1 607 000 968	Gear Housing Assembly w/pos. 14, 30, 33, 38, 51 60, 840, 846	72
35	1 600 205 034	Felt Seal	77	822	1 607 000 959	Gear Cover Assembly w/pos. 28, 32, 35, 37, 60	70
36	1 604 652 016	Brush Spring {2}	27	826	1 607 000 326	Bevel Gear Set	
37	1 600 290 036	Sealing Ring	77	840	1 607 000 206	Spindle Lock Assembly w/pos. 29	81
38	1 600 206 020	Rubber Bearing Sleeve	82	846	1 607 000 316	Washer/Retainer Kit	89
39	1 600 206 030	Rubber Bearing Sleeve	82				
45	1 603 300 019	Nut	89				
51	1 600 200 031	Bushing	51				
53	1 605 190 068	Wire Housing	9				
60	1 603 435 023	Screw {4}	89				
61	2 912 401 038	Screw {6}	89				
63	1 603 410 014	Screw {2}	89				
64	1 603 435 042	Screw {4}	89				
65	2 910 611 020	Screw {3}	89				

Service Notes: