

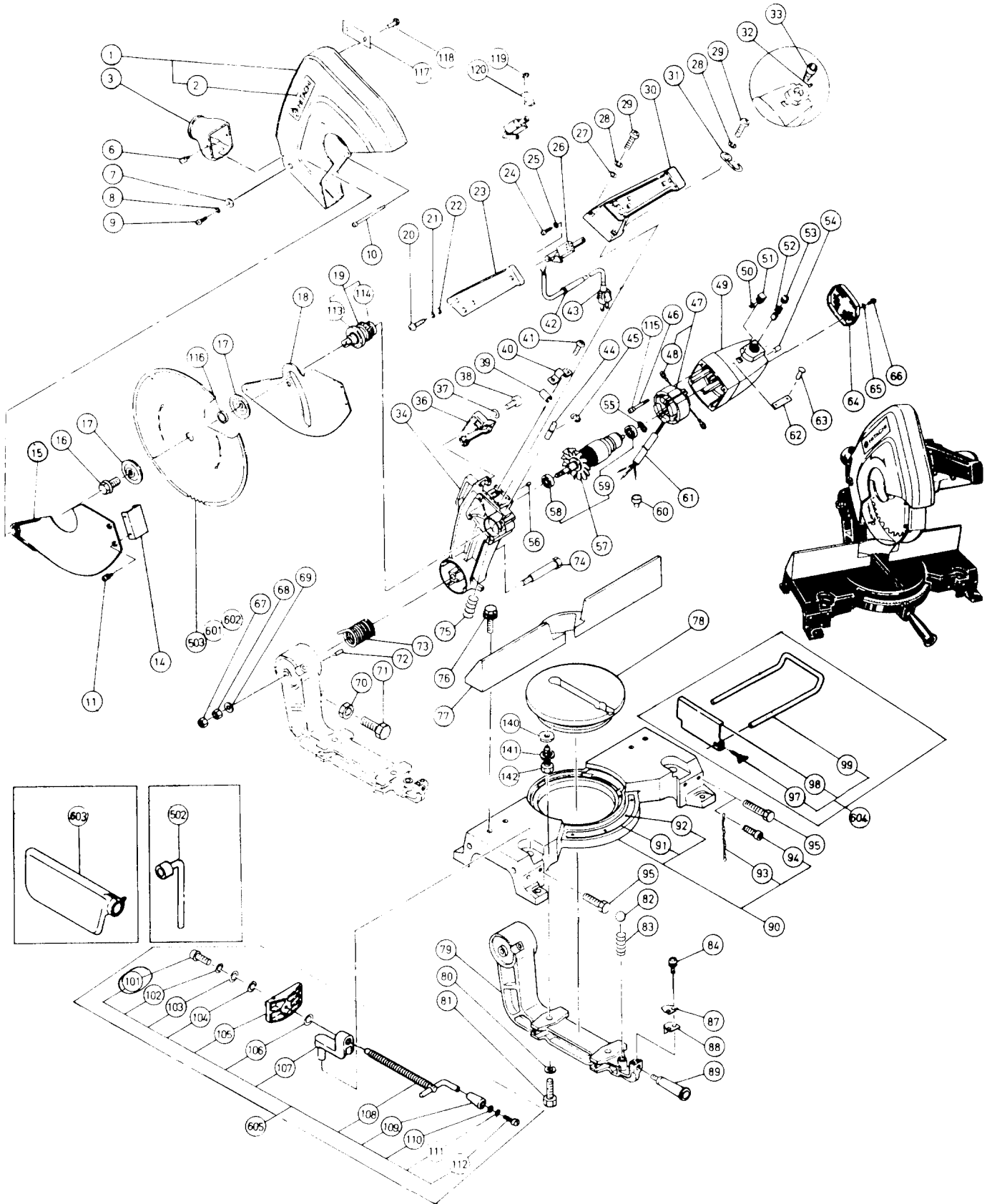

HITACHI

10" MITER SAW

Model C 10FB





HITACHI

10" MITER SAW

Model C 10FB

ITEM NO.	PART NO.	NO. USED	DESCRIPTION	SUPPLY QTY	ITEM NO.	PART NO.	NO. USED	DESCRIPTION	SUPPLY QTY
1	976821	1	Saw Cover (includes Item No.2)		68	972712	1	Nut (I)	
2	998842	1	HITACHI Label (old 974644)		69	949437	1	Bolt Washer M12	10
3	974564	1	Duct		70	949572	1	Lock Nut M10	10
6	986662	2	Machine Screw M4×10		71	949698	1	Bolt M10×30	10
7	*	2	Washer (B)		72	949769	1	Spring Pin D8×40	10
8	949454	2	Spring Washer M5	10	73	974634	1	Spring	
9	949239	2	Machine Screw M5×16	10	74	974550	1	Hinge Shaft Assembly (includes Items 67,68)	
10	976816	4	Machine Tapping Screw D5×75		75	948363	1	Gauge Spring	
11	*	4	Machine Screw M4×8		76	988119	4	Bolt M8×30	
14	*	1	Safety Cover Holder		77	974545	1	Vise (B)	
15	*	1	Safety Cover (B)		78	976803	1	Turn Table	
16	976811	1	Bolt		79	976802	1	Hinge	
17	976810	2	Washer (B)		80	949458	2	Spring Washer M10	10
18	*	1	Safety Cover (includes Item 11)		81	949675	2	Bolt M10×45	10
19	976809	1	Spindle Assembly (includes Item 113,114)		82	959153	1	Steel Ball D12.7	10
20	974589	3	Machine Tapping Screw D4×25		83	967150	1	Spring (C)	
21	949453	3	Spring Washer M4	10	84	976706	2	Machine Screw 5×10	
22	949429	3	Bolt Washer M4	10	87	976826	1	Indicator	
23	976823	1	Handle Cover <i>951898 / 50 30 40</i>		88	976804	1	Spacer	
24	974572	2	Tapping Screw D4×10		89	976805	1	Side Handle	
25	949453	2	Spring Washer M4	10	90	976846	1	Base Assembly (includes Item 91 - 93,95)	
26	976447	1	Trigger Switch <i>988916</i>		91	976801	1	Scale	
27	949432	3	Bolt Washer M6	10	92	949510	4	Rivet D2.5×4.8	10
28	949455	4	Spring Washer M6	10	93	971930	1	Chain	
29	949260	4	Machine Screw M6×25	10	94	949655	1	Hexagon Socket Head Bolt M8×16	10
30	976822	1	Switch Handle		95	949624	3	Bolt M8×20	10
31	974657	1	Chain Hook (A)		97	949404	1	Wing Bolt M6×20	10
32	967508	2	Hexagon Socket Head Slotted Screw M4×5		98	974561	1	Stopper	
33	976807	2	Brush Holder		99	974562	2	Holder	
34	976827	1	Gear Case		100	949254	1	Machine Screw M6×10	10
36	976808	1	Cord Cover		102	949455	1	Spring Washer M6	10
37	949431	2	Bolt Washer M5	10	103	949432	1	Bolt Washer M10	10
38	949239	2	Machine Screw M5×16	10	104	974612	1	Wave Washer M10	
39	—	1	Vinyl Tube D9.5×T0.7×20		105	974548	1	Vise (A)	
40	934028	1	Cord Clip		106	949434	1	Bolt Washer M10	10
41	949216	2	Machine Screw M4×10	10	107	974599	1	Female Screw	
42	940778	1	Cord Armor		108	974600	1	Screw	
43	500241Z	1	Cord		109	967614	1	Feed Grip (A)	
44	974576	1	Stopper Pin		110	976448	1	Washer (B)	
45	974577	1	Retaining Ring 7D		111	949453	1	Spring Washer M4	10
46	944828	2	Machine Screw M5×65		112	949216	1	Machine Screw M4×10	10
47	976817G	1	Stator		113	976828	1	Ball Bearing 62×28ZZ	
48	976831	2	Carbon Brush Terminal		114	609VVM	1	Ball Bearing 609VVMC2PS2S	
49	976806	1	Housing Assembly (includes Item 32,33,54)		115	949454	2	Spring Washer M5	10
50	949555	2	Nut M5	10	117	<i>-976482</i>	1	Caution Plate	
51	974569	2	Nut Cover		118	949510	2	Rivet D2.5×4.8	10
52	999038	2	Carbon Brush	2	140	936311	2	Washer (B)	
53	961781	2	Brush Cap		141	949455	2	Spring Washer M6	10
54	976301	2	Bearing Lock		142	949256	2	Machine Screw M6×16	10
55	976830	1	Wave Washer		183	988894		Tube (D)	
56	976441	1	Bearing Lock		502	988102	1	Box Spanner	
57	976818C	1	Armature Assembly (includes Item 58,59)		503	974604Z	1	Combination Saw Blade 255MM×5 / 8"	
58	6201DD	1	Ball Bearing 6201DDUCMAV2S		505	976836	1	Vise Board Assembly (includes Item	
59	608VVM	1	Ball Bearing 608VVMC2EPS2L					No. 506-508)	
60	959140	1	Connector 50091	10	506	949347	4	Flat Head Screw M8×30	10
61	—	1	Vinyl Tube (AWG3 / 8 (PCV)×220		507	949433	4	Bolt Washer M8	10
62	<i>-976450</i>	1	Name Plate		508	949558	4	Nut M8	10
63	949510	2	Rivet D2.5×4.8	10	601	976473	1	TCT Saw Blade 255MM×5 / 8"	
64	974571	1	Tail Cover		602	976472	1	TCT Saw Blade 255MM×5 / 8"	
65	949453	2	Spring Washer M4	10	603	976478	1	Dust Bag (old 974580)	
66	974572	2	Machine Tapping Screw M4×10		604	974661	1	Guide Assembly (includes Item 97 - 99)	
67	973519	1	Lock Nut		605	974662	1	Vise Assembly (includes Item 101 - 102)	

SERVICE CHANGE

1. Change on Special Washer and Safety Cover:

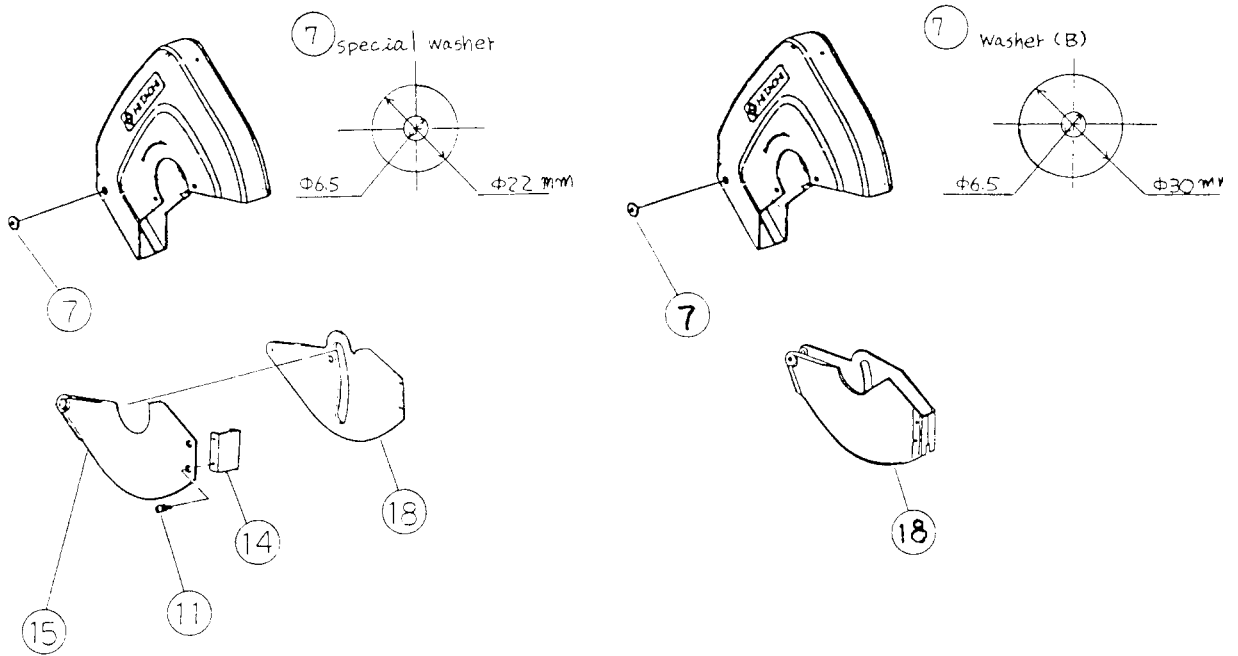

Type 1

Type 2

Item No.	Description	Type 1 (till S #870430)	Type 2 (since S #870431)
7	Special Washer	Part #972256 (Discontinued)	Part #936311 (Washer (B))
11	Machine Screw M4 x 8	Part #976815	---
14	Safety Cover Holder	Part #976814	---
15	Safety Cover (B)	Part #974625 (Discontinued)	---
18	Safety Cover (A)	Part #974623 (Discontinued)	Part #976475 (Safety Cover)

The above parts are completely interchangeable as a set.