

ELECTRIC TOOL PARTS LIST

CORDLESS CIRCULAR SAW Model C 18DMR

2005 · 6 · 1

(E1)

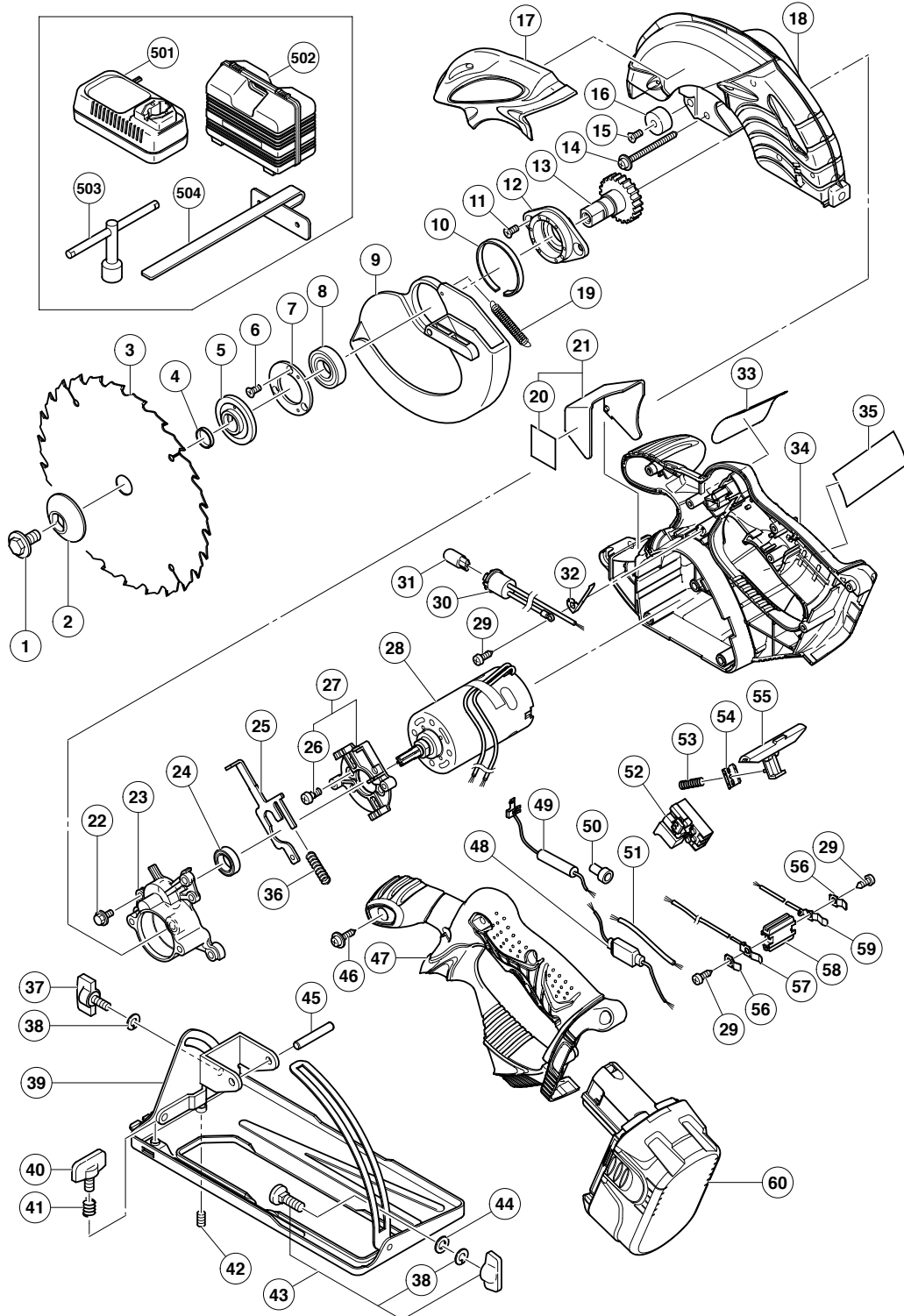

PARTS

C 18DMR

ITEM NO.	CODE NO.	DESCRIPTION	NO. USED	REMARKS
1	998-335	BOLT (LEFT HAND) W/WASHER M7X17.5	1	
2	324-563	WASHER (B2)	1	
* 3	324-295	TCT SAW BLADE 165MM-D30 HOLE-NT24	1	
* 3	324-294	TCT SAW BLADE 165MM-D20 HOLE-NT24	1	FOR NZL, AUS, CHN
* 3	324-293	TCT SAW BLADE 165MM-D15.9 HOLE-NT24	1	FOR USA, CAN
* 3	324-615	TCT SAW BLADE 165MM-D15.9 HOLE-NT24	1	FOR FRA
* 4	990-100	RING D15.9/I.D14.5	1	FOR FRA, USA, CAN
* 5	317-465	WASHER (A2)	1	
* 5	324-569	WASHER (A3)	1	FOR GBR, FRG, FRA, NOR, SWE, DEN
* 5	317-466	WASHER (A1)	1	FOR FRA, USA, CAN
6	308-773	SEAL LOCK FLAT HD. SCREW M3X12	3	
7	308-362	BEARING COVER	1	
8	600-2VV	BALL BEARING 6002VVCMP2L	1	
9	324-567	PROTECTIVE COVER	1	
10	318-192	BUSHING	1	
11	305-568	SEAL LOCK FLAT HD. SCREW M5X12	2	
12	308-361	BEARING HOLDER	1	
13	324-564	GEAR	1	
14	317-449	TAPPING SCREW (W/FLANGE) D5X50	3	
15	949-793	FLAT HD. SCREW M5X20 (10 PCS.)	1	
16	310-842	CUSHION	1	
17	324-560	HITACHI PLATE	1	
18	324-566	SAW COVER	1	
19	317-203	RETURN SPRING	1	
20		LABEL (LC)	1	
21	324-577	LIGHT COVER ASS'Y	1	INCLUD. 20
22	317-196	NYLOCK BOLT (W/FLANGE) M4X12	2	
23	324-565	INNER COVER (B)	1	
24	609-VVM	BALL BEARING 609VVC2PS2L	1	
25	324-568	LOCK LEVER	1	
26	317-914	SPECIAL BOLT M5	2	
27	324-578	INNER COVER (A) ASS'Y	1	INCLUD. 26
28	324-572	MOTOR (B)	1	
29	958-715	TAPPING SCREW D4X10	3	
30	319-820	SOCKET	1	
31	315-229	LAMP (12V 5W)	1	
32	319-823	TERMINAL (D)	1	
33		NAME PLATE	1	
34	324-575	HOUSING	1	
* 35		CAUTION PLATE	1	FOR USA, CAN
36	961-803	SPRING	1	
37	308-364	WING BOLT (A) M6X15	1	
38	948-167	SUPER LOCK WASHER M6	2	
39	324-561	BASE ASS'Y	1	INCLUD. 37, 38, 40-42
40	324-562	KNOB BOLT	1	
41	947-859	LOCK SPRING	1	
42	302-469	SLOTTED HD. SET SCREW (SEAL LOCK) M6X6	1	
43	314-620	BOLT ASS'Y (SQUARE) M6X22	1	INCLUD. 38
44	949-425	WASHER M6 (10 PCS.)	1	
45	949-750	ROLL PIN D6X50 (10 PCS.)	1	
46	305-812	TAPPING SCREW (W/FLANGE) D4X16 (BLACK)	6	

