

Rotabroach[®]

PORTABLE MAGNETIC DRILLS

OPERATOR'S MANUAL

HMD100



FOR USE WITH "17,000-SERIES" ROTABROACH CUTTERS

HOUGEN® ROTABROACH®

Portable Magnetic Drill

Model HMD100

Welcome to Hougen

Congratulations on your purchase of the Hougen® Rotabroach® Portable Magnetic Drill. Your model is designed to produce superior holes quickly and efficiently. Through constant innovation and development, Hougen is committed to provide you with hole-producing tools and products to help you be more productive.

Before attempting to operate your new Portable Magnetic Drill, please read all instructions first. These include the Operator's Manual and Warning Label on the unit itself. With proper use, care, and maintenance, your model will provide you with years of effective hole drilling performance. Once again, thank you for selecting our product and welcome to Hougen.



INDEX

Contents Checklist	2
Important Safety Instructions	3
Review of Controls	5
“17,000-Series” Cutter Installation	5
Operating Instructions	6
Control Panel Diagram	7
Hookup Diagram	7
Drill Parts Diagram	8
Parts List	9
Other Hougen Products	9
Motor Diagram and Parts List	10
Limited Warranty	11
Factory Authorized Warranty Repair Centers.	12

CONTENTS CHECKLIST

Check the contents of the carrying case to be sure the following items are included with your new Magnetic Drill.

- | | |
|---|--|
| <input type="checkbox"/> Carrying Case 17052 | <input type="checkbox"/> Finishing Plug |
| <input type="checkbox"/> Safety Strap 17059 | <input type="checkbox"/> Stick Lubricant 11746 |
| <input type="checkbox"/> Cutting Fluid Pint 11741 | <input type="checkbox"/> Feed Handle/knob 17071 (2) |
| <input type="checkbox"/> Operator's Manual 17061 | <input type="checkbox"/> Warranty/Registration card* |

* Please take the time NOW to fill out your Warranty/Registration card and return it to Hougen Mfg. within 10 days.

Important Safety Instructions

1. Read All Instructions

2. Grounding Instructions

This tool should be grounded while in use to protect the operator from electric shock. The tool is equipped with a 3-conductor cord and a 3-prong grounding type plug to fit the proper grounding type receptacle. The green (or green and yellow) conductor in the cord is the grounding wire. Never connect the green (or green and yellow) wire to a live terminal. Your unit is for use on 115V, and has a plug that looks like that shown in sketch (A). An adapter, see sketches (B) and (C), is available for connecting sketch (A) type plugs to 2-prong receptacles. The green-colored rigid ear, lug, or the like, extending from the adapter must be connected to a permanent ground, such as a properly grounded outlet box.

Note: Use of a grounding adapter is prohibited in Canada by Part I of the Canadian Electrical Code.

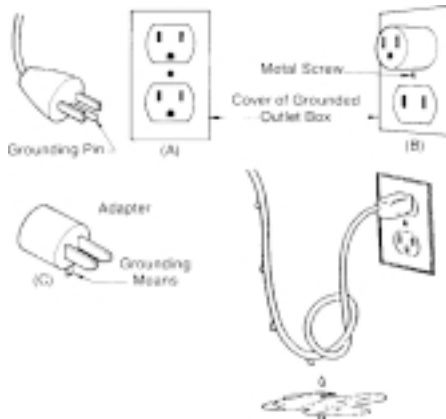

3. Safe Electrical Connection

Your HMD100 is rated for use on 120VAC at 50-60Hz. Do not attempt to use drill on power sources rated other than this. Wet electrical connections are shock hazards. To prevent the cutting fluid from traveling along the cord and contacting the plug or power outlet, tie a drip loop as shown above. Also elevate extension cords or gang box connections.

Length of Cord, Feet	Recommended Wire Gauge	Recommended Wire Gauge
	115V Motor 10-12 Amps	230V Motor 5-6 Amps
Up to 25	16	18
26-50	14	18
51-100	10	16
101-200	8	14
201-300	6	12
301-500	4	10

4. Extension Cords

Use only 3-wire extension cords that have 3-prong grounding type plugs and 3-pole receptacles that accept the tool's plug. Replace or repair damaged cords. Make sure the conductor size is large enough to prevent excessive voltage drop which will cause loss of power and possible motor damage.

5. Do Not Force Tool

It will do the job better and faster at the rate for which it was intended.

6. Keep Work Area Clean

Cluttered areas and benches invite injuries. Keep dirt and chips from under magnet and Rotabroach Cutter area. Do not attach magnet to surfaces where paint is thick or peeling.

7. Consider Work Area Environment

Do not expose tool to rain.
Do not use tool in damp or wet locations.
Keep work area well lit.
Do not use tool in presence of flammable liquids or gases. Disconnect from power source when changing cutters or maintaining drill.

8. Guard Against Electric Shock

Prevent body contact with grounded surfaces. For example: pipes, radiators, ranges, refrigerator enclosures.

9. Keep Children Away

Do not let visitors contact tool. All visitors should be kept away from work area while in use.

10. Store Idle Tools

When not in use, tools should be stored in a dry, and high or locked-up place — out of reach of children.

11. Use Right Tool

Do not force small tool or attachment to do the job of a heavy duty tool.
Do not use tool for purpose not intended — for example — do not use a circular saw for cutting tree limbs or logs.

12. Secure Work

Use clamps or a vise to hold work. It is safer than using your hand and it frees both hands to operate tool.

13. Always Wear Safety Glasses or Goggles

14. Dress Properly

Do not wear loose clothing or jewelry. They might entangle with spinning chips or get caught in moving parts. Rubber gloves and non-skid footwear are recommended when working outdoors. Wear sturdy leather gloves when working indoors. Wear protective hair covering to contain long hair.

Important Safety Instructions (Continued)

15. Do Not Abuse Cord

Never carry drill unit by its cord or yank it to disconnect from receptacle.
Keep cord away from heat, oil, and sharp edges.

16. Do Not Overreach

Keep proper footing and balance at all time.

17. Maintain Tools With Care

Keep tools sharp and clean for better and safer performance.

Do not use dull or broken Rotabroach Cutters. Follow instructions for lubricating and changing accessories.

Inspect tool cords periodically and, if damaged, have repaired by authorized service facility.

Inspect extension cords periodically and, if damaged, have repaired by authorized service facility.

Keep handles dry, clean, and free from oil and grease.

18. Disconnect Tools

Disconnect when not in use, before servicing, and when changing Rotabroach Cutters or accessories.

19. Remove Adjusting Keys and Wrenches

Form a habit of checking to see that keys and wrenches are removed from tool before turning it on.

20. Check Damaged Parts

Before further use of the drill, a part that is damaged should be carefully checked to determine that it will operate properly and perform its intended function.

Check for alignment of moving parts, binding of moving parts, breakage of parts, mounting, and any other conditions that may affect its operation. A part that is damaged should be properly repaired or replaced by an authorized service center unless otherwise indicated elsewhere in this operator manual. Do not operate tool if switch does not turn it on and off.

21. Stay Alert

Watch what you are doing.

Use common sense.

Do not operate tool when you are tired.

Have defective switches replaced by authorized service center.

22. Outdoor Use Extension Cords

When tool is used outdoors, use only extension cords intended for use outdoors and so marked.

23. Additional Safety Precautions

Arbor and cutter should never be used as a handhold. Keep hands and clothing away from all moving parts. Do not use Rotabroach Cutters where ejected slug might cause injury (slug ejected at end of cut).

Also, adhere to all operating instructions. Do not drill through any surface that may contain live electrical wiring. Drilling into a live wire could cause exposed metal parts of the drill to be made live. Remove chips wrapped around Rotabroach Cutter and arbor after each hole.

With motor off and power disconnected, grasp chips with leather gloved hand or pliers and pull while rotating counterclockwise. Should the cutter become jammed in the work, stop the unit immediately to prevent personal injury. Disconnect the drill from the power supply and loosen jammed cutter by turning the arbor counterclockwise. Never attempt to free the jammed cutter by starting the motor. Service at authorized repair center only.

24. Non-Conforming Cutting Tools

Your Magnetic Drill is designed to use Hougén Rotabroach Cutters. The use of drilling tools having different shank styles is not recommended as they may not tighten securely in the drill arbor with risk of accident or injury.

25. Operating Near Welding Equipment

When operating your Magnetic Drill near an arc welder, it is important that they are connected to the same Earth Ground. If they are not, severe damage to the unit, particularly the power cord, could occur. This could also result in personal injury to the operator.

26. Notice

This unit is an Industrial Portable tool and is not designed for production. If this product is used as a production unit, internal gear failure could occur and cause serious damage.

27. Circuit Breaker

Changing of the circuit breaker to a higher amp rated breaker, or by-passing the circuit breaker is not recommended and is cause for cancelation of the product warranty.

28. Circuit Breaker Operation

The circuit breaker is a thermal circuit breaker. When it reaches the higher temperature rating it will trip and cause the unit to shut down. This is a protection device and can be reset after 5 to 10 seconds of cool down period. To reset the circuit breaker, press the breaker button back in. If it does not reset, let the unit cool a little longer until you can push the button in and it stays in position.

Review of Controls

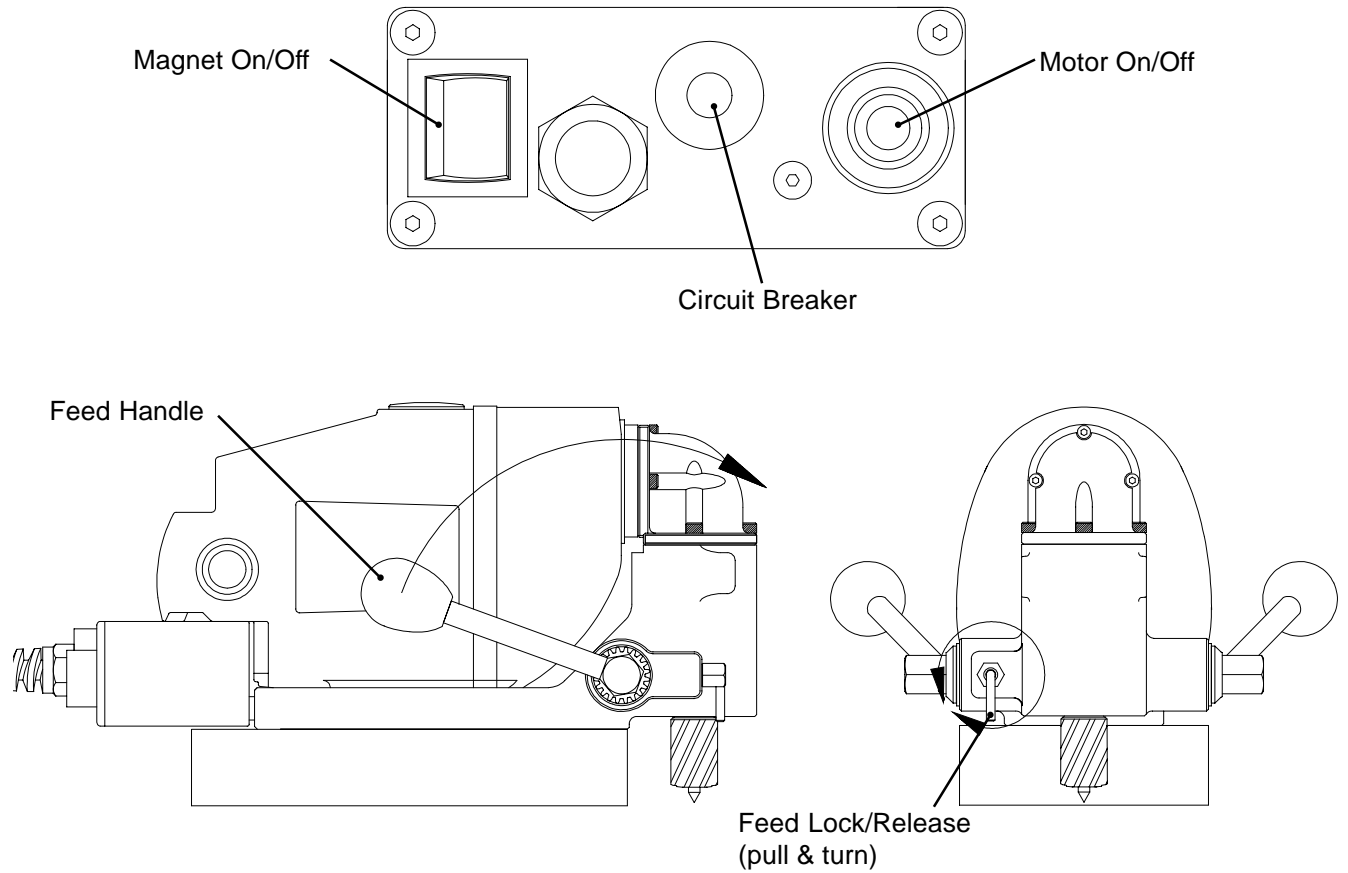

“17,000-Series” Cutter Installation

1. Disconnect machine from power source.
2. Insert pilot into cutter.
3. Align flat on shank with pin in spindle.
4. Insert cutter into spindle.
5. Give cutter 1/4 turn in opposite direction of flutes.

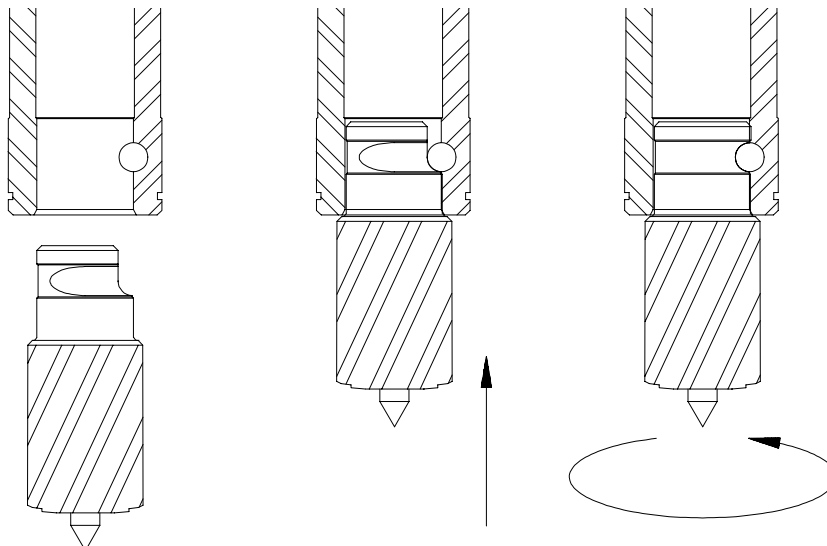

Operating Instructions

Place drill on material and locate for drilling hole.

Press magnet switch to "ON"

Thread safety strap through opening between motor and drill housing. Ensure that strap does not interfere with operation of feed handles. Insert tab of strap into buckle. Cinch strap tight to material and drill housing. Check for slack and adjust as needed.

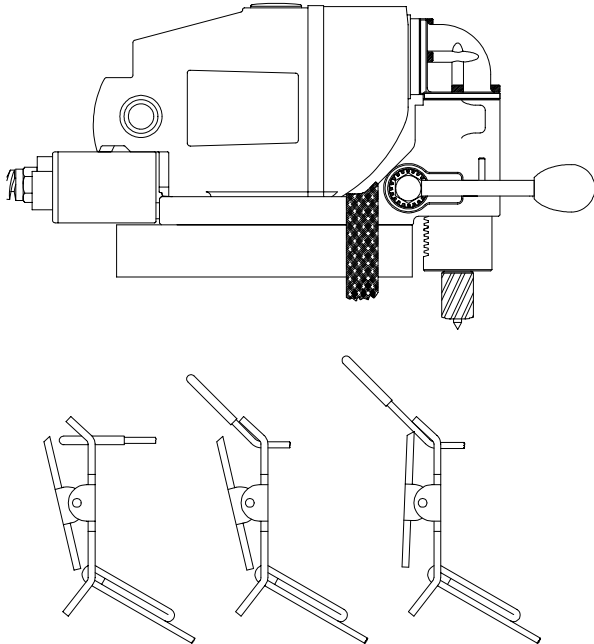

CAUTION:

- Keep strap clear of cutting area, chips, and rough edges on material.
- Inspect strap periodically for fraying and damage. Do not use a damaged safety strap.

Apply liberal amount of cutting fluid or stick lubricant to cutter. Additional lubrication may be needed to complete cut.

Disengage feed lock/release.

Press and hold motor switch. (Note: Switch must be held in "ON" position while cutting)

Feed Rotabroach Cutter slowly into workpiece. Only after cutting path is established to a depth of about 1/16" can additional force be applied to feed handles.

Ease up on feed pressure as cutter starts breaking through.

CAUTION: Do not over-feed cutter. Excessive feed pressure may cause the magnet to break free from material.

17,000 FEATURES AND DESCRIPTION:

Second layer penetration may be difficult. Slight additional feed pressure may be required (avoid over-feed as note above).

If unable to penetrate second layer, withdraw cutter from material ejecting slug and clean away any remaining chips. Feed cutter in hole and continue cut.

Release motor switch when cut is finished.

Fully retract cutter from material, ejecting the slug.

Engage feed lock/release.

Remove safety strap.

Turn magnet switch to "OFF" position.

CAUTION: Retain firm hold on drill to prevent dropping.

Cutter I.D. may collect chips, restricting depth of cut. Cutter should be frequently inspected and any chips or debris removed.

OPTIONAL FEED METHODS:

- 5/8" Box Wrench
- Ratchet with 5/8" Socket (shown below)
- NO PLIERS OR OPEN END WRENCH (will damage threaded feed handle mounting holes)

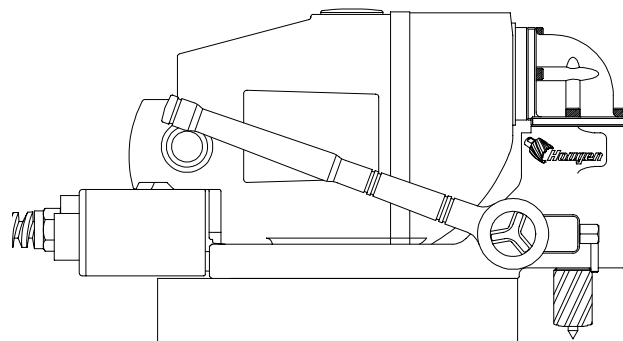

Control Panel /Hookup Diagram

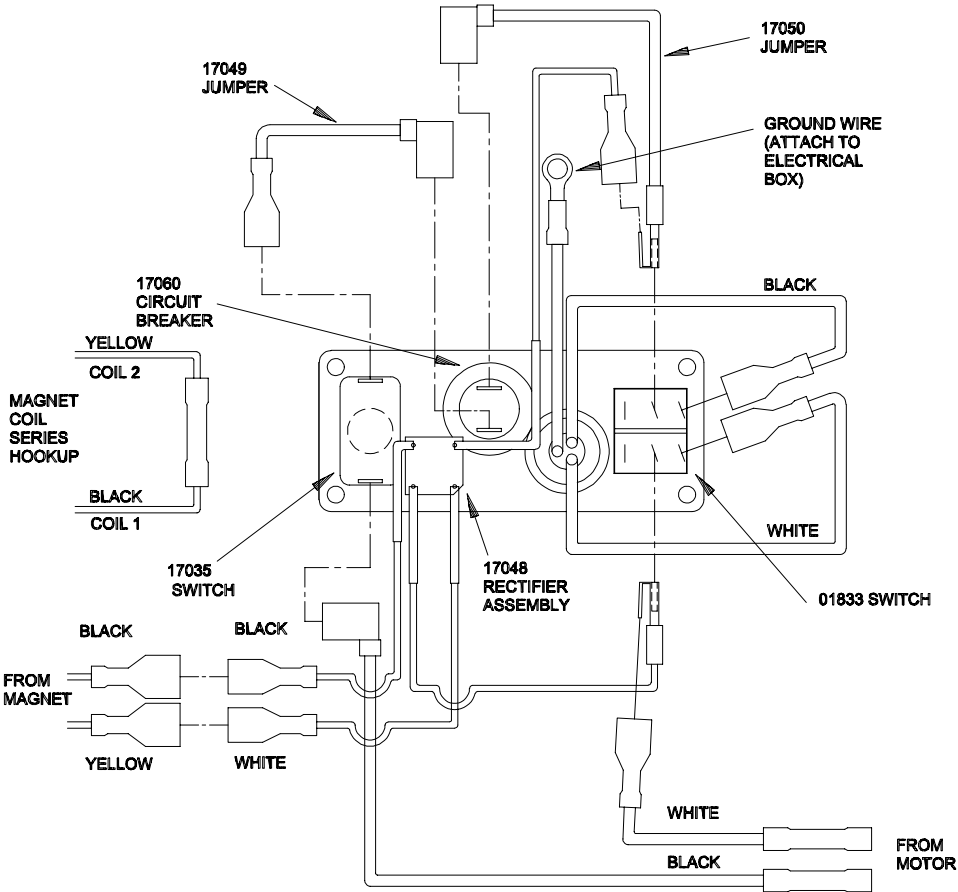
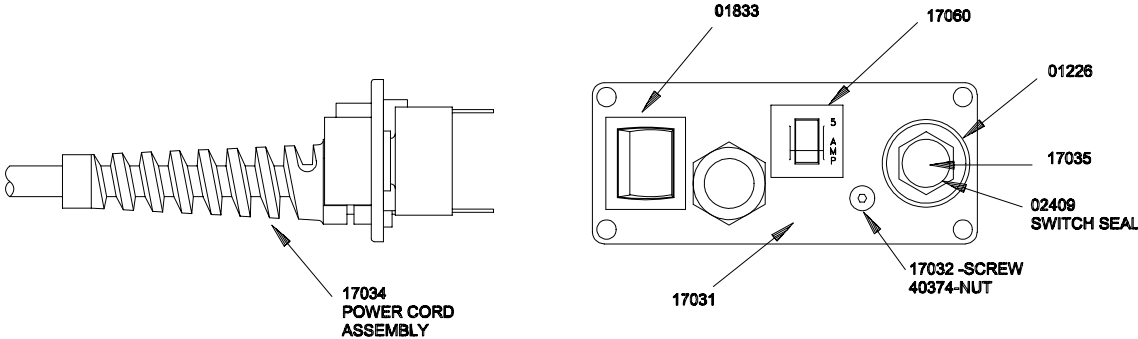

HMD100 Drill Parts Diagram

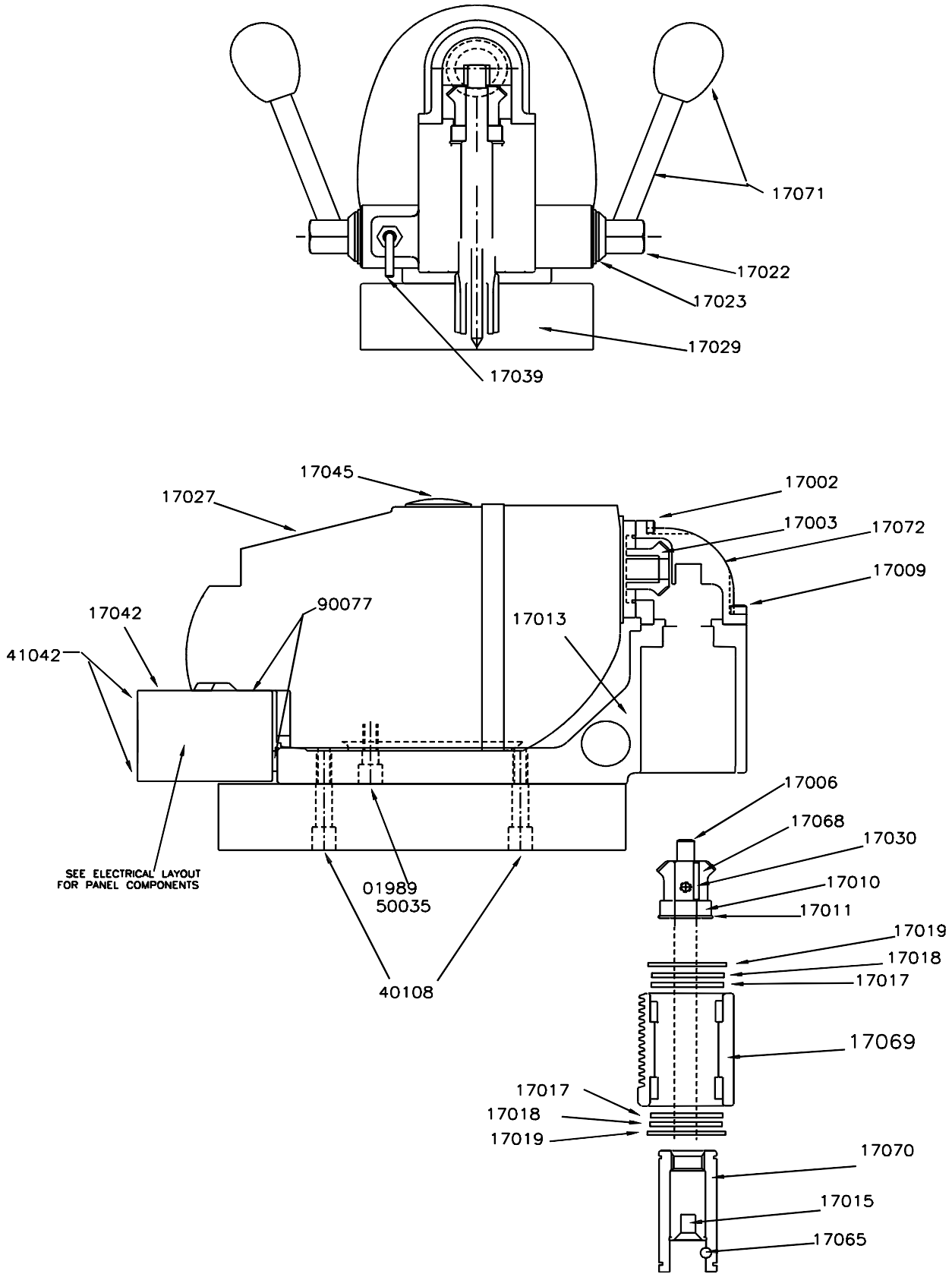

HMD100 Parts List

Part No.	Description	Qty.
01226	SWITCH GUARD	1
01833	ROCKER SWITCH	1
01989	1/4-28 X 3/4 SHCS	2
17002	SCR-SHC #6-32 X 1/2 SHCS	3
17003	LH SPIRAL MITER GEAR	1
17006	SPLINE SHAFT	1
17009	SCR-SHC #8-32 X 1/2 SHCS	3
17010	BALL BEARING	1
17011	RETAINING RING	1
17013	HOUSING	1
17015	1/4-28 X 1/2 FHSCS	1
17017	NYLON THRUST WASHER	2
17018	STEEL THRUST WASHER	2
17019	RETAINING RING	2
17022	FEED GEAR	1
17023	SNAP RING	1
17027	MOTOR ASSEMBLY	1
17029	MAGNET ASSEMBLY	1
17030	3/32 X 3/32 X 5/8 KEY	1
17031	FACEPLATE	1
17032	SCREW	1
17034	POWER CORD ASSEMBLY	1
17035	SWITCH-MOMENTARY	1
17037	CONTROL PANEL ASSEMBLY	1
17039	SPRING PLUNGER	1
17042	ELECTRICAL BOX	1
17045	FINISHING PLUG	1
17048	RECTIFIER ASSEMBLY	1
17049	JUMPER-MOTOR SWITCH	1
17050	JUMPER-MAGNET SWITCH	1
17060	CIRCUIT BREAKER	1
17065	DOWEL PIN	1
17068	RH SPIRAL MITER GEAR ASSEMBLY	1
17069	QUILL ASSEMBLY	1
17070	ARBOR ASSEMBLY	1
17071	FEED HANDLE ASSEMBLY	2
17072	GEAR BOX CAP ASSEMBLY	1
40108	1/4-20 X 1-1/4 SHCS	4
40374	NUT	1
41042	8-32 X 3/8 BHCS	4
50035	1/4 LOCK WASHER	2
90077	10-32 X 1/2 BHCS	4

Hougen Holemaking Products

“17,000-Series” Rotabroach Cutters for HMD100”

The “17,000-Series” Rotabroach Annular cutters are made specifically for the HMD100. They are equipped with a tool-less quick release shank, and can drill up to 3/4" deep in single or stacked plate. They are made of premium high speed steel and available in diameters from 5/8" to 1-1/16".



*** NEW ***

“17,000” Series Cutter Kit -
Hougen part number 17001”
Kit includes all 10 cutters listed plus 2 pilots all in a handy case. Contact your local distributor for pricing

Part No.	Diameter
17116	1/2"
17118	9/16"
17120	5/8"
17122	11/16"
17124	3/4"
17126	13/16"
17128	7/8"
17130	15/16"
17132	1"
17134	1-1/16"

Motor Diagram and Parts List

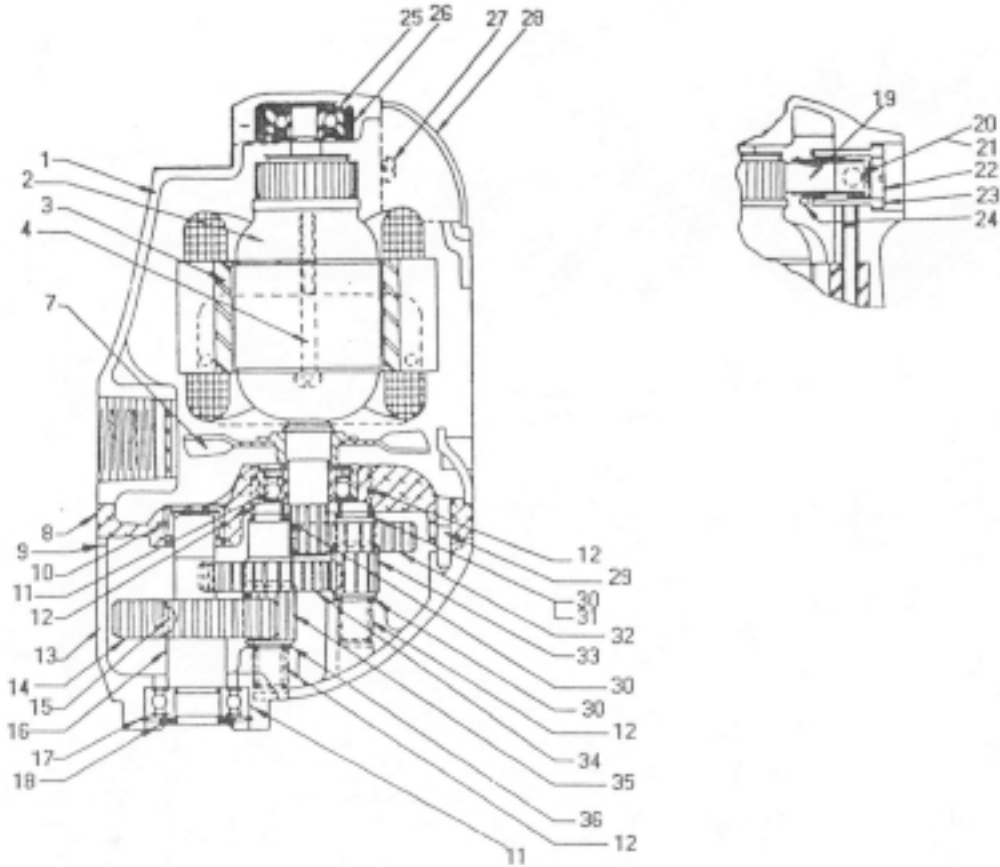

Item No.	Part No.	Description	Qty.	Item No.	Part No.	Description	Qty.
1	BD-144266-00	Field Case	1	19	10995	Brush Assy. (pair)	1
2	BD-445786-31	Armature	1	20	BD-376	Set Screw	2
3	BD-400322-71	Field	1	21	BD-400718	Nylon Ball	2
4	BD-12158	Screw & Washer	2	22	BD-46210	Brush Holder Plug	2
6	BD-133410	Fan	1	23	BD-61208-03	Brush Holder	2
8	BD-51404-03	Gear Case Cover	1	24	BD-46212	Brush Lead Terminal	2
9	BD-143691-00	Gasket	1	25	BD-330003-04	Ball Bearing	1
10	BD-135937	Needle Bearing	1	26	BD-132332	Bearing Sleeve	1
11	BD-700964	Ball Bearing	2	28	BD-21235	Brush Cover	1
12	BD-21246	Needle Bearing	4	30	BD-51407	Fiber Washer	4
13	04370	Gear Case	1	31	BD-51405	1st. Inter Gear Assy.	1
14	BD-400147	Spindle Gear	1	32	BD-49082	1st.133410 Inter Gear	1
15	BD-7027	Key	1	33	BD-51401	1st. Inter Pinion	1
16	BD-133316-01	Spindle	1	34	BD-51406	2nd. Inter Gear Assy.	1
17	BD-99022-02	Retaining Ring	1	35	BD-21822	2nd. Inter Gear	1
18	10992	Washer	1	36	BD-51402	2nd. Inter Pinion	1

Hougen Holemaking Products

Rotabroach Portable Magnetic Drills

Rotabroach®.. the Work Anywhere Portable Magnetic Drills. No matter what you do -fabricate, install, maintain, repair, retrofit, or manufacture, Hougen Rotabroach Portable Magnetic Drills put superior holemaking capabilities in your hands. On-site, at-the-work drilling that's easier, faster, and safer, wherever electrical power is available.

A series of twelve models lets you custom match power and features to your specific application needs. You can choose from economical light duty models for drilling holes up to 1-3/8" diameter and 2" depth of cut, while others have the might to produce 3-1/16" holes thru 3" thick material. Some with power feed, some with multi-speed spindles. But all have incomparable performance for fast drilling, maneuverability, and lightness, resulting in minimal operator fatigue, fast setups, and improved productivity.

With Rotabroach Portable Magnetic Drills, you save time by no longer moving large, heavy structures to machines or using hand-held drills that can be inaccurate and tiring.

Model	Description	Max. Capacity		Cutter Series
		Dia.	Depth	
HMD100	Complete Drill w/Case 450 RPM Motor 115V	1-1/16"	3/4"	"17,000" *
10904	Complete Drill w/Case 450 RPM Motor 115V	1-3/8"	2"	"12,000"
HMD500	Complete Two-speed Drill w/Case 115V	2-3/8"	3"	
10909	Complete Drill 350 RPM Motor 230V	2-1/16"	3"	
10909S	Complete Drill 350 RPM Motor 230V			
10914	Complete Drill 350 RPM Motor 115V			
10914S	Complete Drill 350 RPM Motor 115V			
10925	Power Feed 350 RPM Motor 115V			
10926	Power Feed Drill 350 RPM Motor 230V			
10915	Complete Multi-speed Drill 115V	3-1/16"	3"	"42,000" & "43,000"
10916	Complete Multi-speed Drill 230V			

* "17,000-Series" Rotabroach Cutters for use with HMD100 only.

Commercial / Industrial Limited Warranty

Hougen Manufacturing, Incorporated warrants its Portable Magnetic Drills for one (1) year and its Electro-hydraulic Hole Punchers and other products for ninety (90) days from date of purchase against defects due to faulty material or workmanship and will repair or replace (at its option) without charge any items returned. This warranty is void if the item has been damaged by accident or unreasonable use, neglect, improper service, or other causes not arising out of defects in material or workmanship. No other expressed warranty is given or authorized. Hougen Manufacturing, Inc. disclaims any implied warranty of MERCHANTABILITY or FITNESS for any period beyond the expressed warranty and shall not be liable for incidental or consequential damages. Some states do not allow exclusions of incidental or consequential damages or limitation on how long an implied warranty lasts and, if the law of such a state governs your purchase, the above exclusion and limitation may not apply to you. This warranty gives you specific legal rights and you may also have other rights which vary from state to state.

To obtain warranty service, return the item(s), transportation prepaid, to your nearest Factory Authorized Repair Center or to Hougen Manufacturing, Inc., 3001 Hougen Drive, Swartz Creek, Michigan 48473.

Hougen Drills (Rotabroach Cutters) are warranted against manufacturing defects only. Subject to Hougen Manufacturing inspection.

THIS WARRANTY IS IN LIEU OF ANY OTHER WARRANTY, EXPRESSED OR IMPLIED, INCLUDING ANY

Factory Authorized Warranty Repair Centers

United States - East

A&A Industrial Supplies Inc.
251 Meacham Ave.
Elmont, NY 11003
(516) 437-0114

Awisco Repair Center
55-16 43rd Ave.
Maspeth, NY 11378
(718) 786-7788

Boyer Machinery Co.
2280 Wyandotte Road
Willow Grove, PA 19090
(215) 657-2242

Colony Hardware Supply Co.
15 Stiles Street
New Haven, CT 06512
(203) 466-5252

Hanes Supply Repair Center
10 Cairn Street
Rochester, NY 14609
(716) 826-2636

N.H. Bragg & Sons
90 Perry Road
Bangor, ME 04401
(207) 947-8611

Pennsylvania Tool Sales
and Service, Inc.
625 Bev Road
Youngstown, OH 44512
(330) 758-0845

Weld Tooling Corp.
3001 W. Carson Street
Pittsburgh, PA 15204
(412) 331-1776

West

ATS Repair Center
2400 West Directors Row
Salt Lake City, UT 84125
(801) 972-3182

Caltool Industrial Supply
470 Hester Street
San Leandro, CA 94577
(510) 729-0600

Kenbil Service Co.
2900 Adams St., B-15
Riverside, CA 92504
(909) 689-6633

Quimby Welding Repair
1603 Northwest 14th Ave.
Portland, OR 97209
(503) 221-1100

A.C.C. Machinery Co., Inc.
747 Grand Ave.
Phoenix, AZ 85007
(602) 258-7330

Southeast

Gardner Southeast Repair
807 Meroney Street
Chattanooga, TN 37405
(423) 756-4722

Mid-South Welding Supply
505 51st. Avenue
Meridian, MS 39307
(601) 483-9331

South

Allied Sales & Service Co.
1508 River Oaks Rd., West
Jefferson, LA 70123
(504) 734-9566

Wilbanks Repair Center
5532 S. 94th East Ave.
Tulsa, OK 74145
(918) 627-8445

Midwest

Ceekay Repair Center
5835 Manchester Ave.
St. Louis, MO 63110
(314) 644-3500

Miller Industrial Supply Co.
1695 N. 21st
Decatur, IL 62525
(217) 428-7787

Hougen Manufacturing, Inc.
3001 Hougen Drive
Swartz Creek, MI 48473
(810) 635-7111

Westbrook Engineering
23501 Mound Road
Warren, MI 48091
(810) 759-3100

Southwest

Arcmaster Repair Center
301 Woodrow Ave
Fort Worth, TX 76105
(817) 531-8101

Rex Supply Repair Center
3715 Harrisburg
Houston, TX 77003
(713) 222-2251

Canada

OK Power Tool
14740 115 Avenue
Edmonton, Alberta
Canada T5M 3B9
(403) 454-5111

Outiltech Orleans, Inc.
5695 Rue Rideau
Quebec, Quebec
Canada G2E 5V9
(418) 877-7776

Edward H. Pope, Ltd.
10 Imperial Court
Brampton, Ontario
Canada L6T 4X4
(905) 458-4800

Power Tool Clinic
19835-56 Ave
Langley, B.C.
Canada V3A 3V1
(604) 530-3550

O.T.I. Repair Center Inc
195 Rue Henry Bessemer
Bois Des Filion
Quebec Canada J6Z 4S9
(450) 965-2224

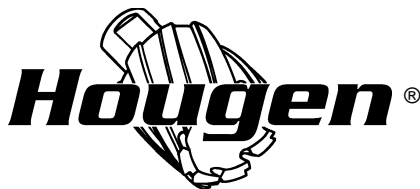

Hougen Manufacturing, Inc.

P.O. Box 2005 • Flint, MI 48501-2005
3001 Hougen Drive • Swartz Creek, MI 48473
Phone (810) 635-7111 • FAX (810) 635-8277
Email: hougenco@tir.com
Online: www.hougen.com

